

# Orchard Machinery Corporation

2700 Colusa Highway, Yuba City CA 95993

Tel: 530-673-2822 • Fax: 530-673-0296 • www.shakermaker.com

## FE-36

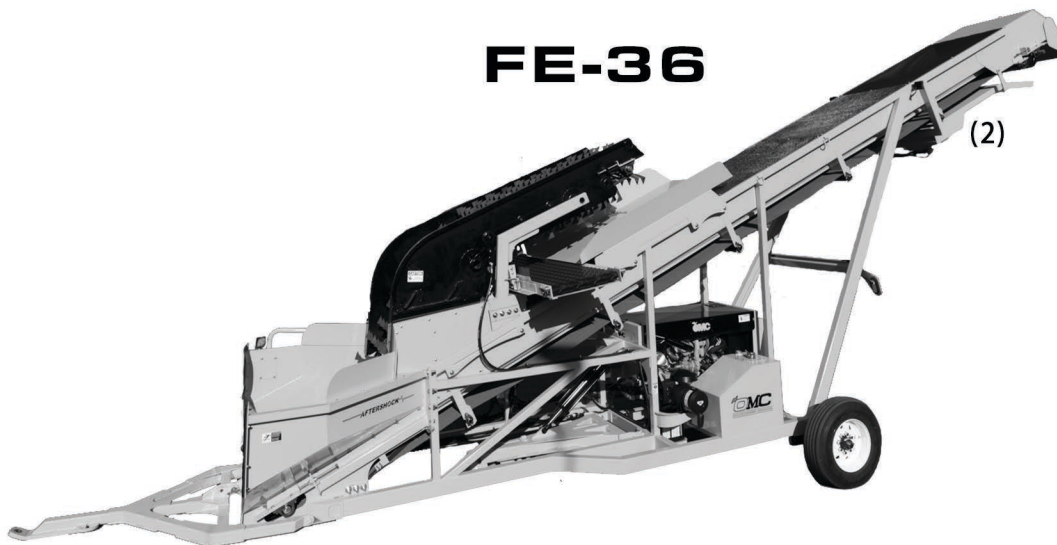

### Standard Features:

- F3.8 74HP Stage V Cummins turbo-diesel engine
  - No DEF
- 36-inch wide Giant Z top belt
- Swingarm controls
- Hydraulic top deflector
- LED night lights
- Tow lights with turn signals
- Powder coat finish
- 235/75R-17.5 tires (6,000 lb rating)
- Hydraulic lift - Skid plate
- 10,000lb Torflex axle

### OPTIONS:

- Desticker with sliding stick conveyor (1)
- Cleated belts (in place of Z top)
- Electric brakes
- Leaf fan (2)

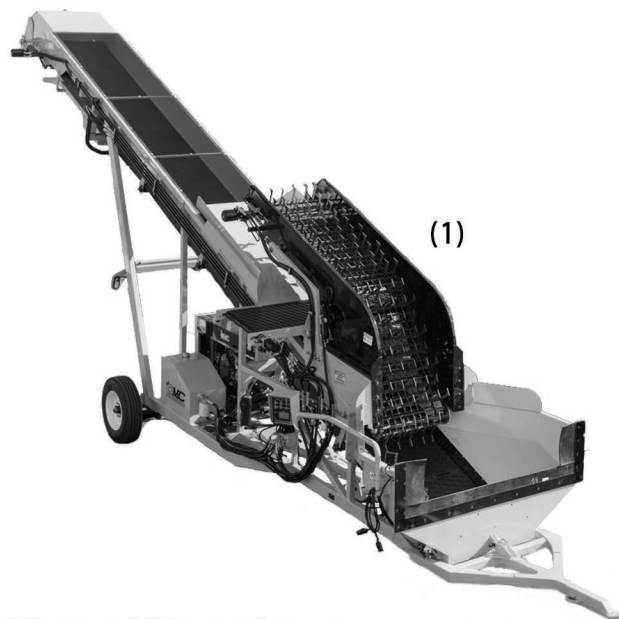

### Specifications:

- Length: 38 feet, 6 inches
- Width: 105 inches
- Discharge Height: 14 feet, 6 inches
- Towing Height: 13 feet, 6 inches
- Towing Length: 40 feet, 6 inches
- Fuel capacity: 44 gallons

Strong on Parts  
and Service

**OMC**

Since 1961